

A faint, dotted world map is visible in the background of the slide. A thick blue horizontal bar with a slight 3D effect is positioned above the main title.

Make Machine-Learning and Predictive Maintenance Part of Your Daily Operation

Angela Saffin

Portfolio Leader, Analytics Solutions, Digital Aviation Solutions

Connected Aviation Intelligence Summit 2023

Data-Informed Decision-Making



Data-informed insights broaden perception, deepen understanding and illuminate solutions.

Reduce Risk | **Decrease Costs** | **Increase Performance**

Analytics enable organizations to optimize operations and better prepare for the future.

Keys to Data-Driven Insights



DATA

30X

more data on newest wide bodies
than previous generations



PEOPLE

T to π

Broad engineering skills and deep domain
knowledge + data science expertise



TECHNOLOGY

Innovation

Analytics, machine learning,
artificial intelligence

Keys to Data-Driven Insights



DATA

30X

more data on newest wide bodies than previous generations



PEOPLE

T to π

Broad engineering skills and deep domain knowledge + data science expertise



TECHNOLOGY

Innovation

Analytics, machine learning, artificial intelligence

OPPORTUNITIES

Predictive maintenance

Fuel efficiency

Emissions reduction

Enhanced safety

Increased fleet reliability

Keys to Data-Driven Insights



DATA

30X

more data on newest wide bodies than previous generations



PEOPLE

T to π

Broad engineering skills and deep domain knowledge + data science expertise



TECHNOLOGY

Innovation

Analytics, machine learning, artificial intelligence

CHALLENGES

Time-consuming data processing

Inconsistent methods and tools

Manual curation and distribution

Duplicative efforts

Dated, complicated analysis tools

Predictive Maintenance Objective

Identify the optimum time to intervene to prevent unscheduled maintenance and maximize usable condition.

- Leverage data to accurately predict component failure
- Schedule proactive maintenance to maximize operational efficiency

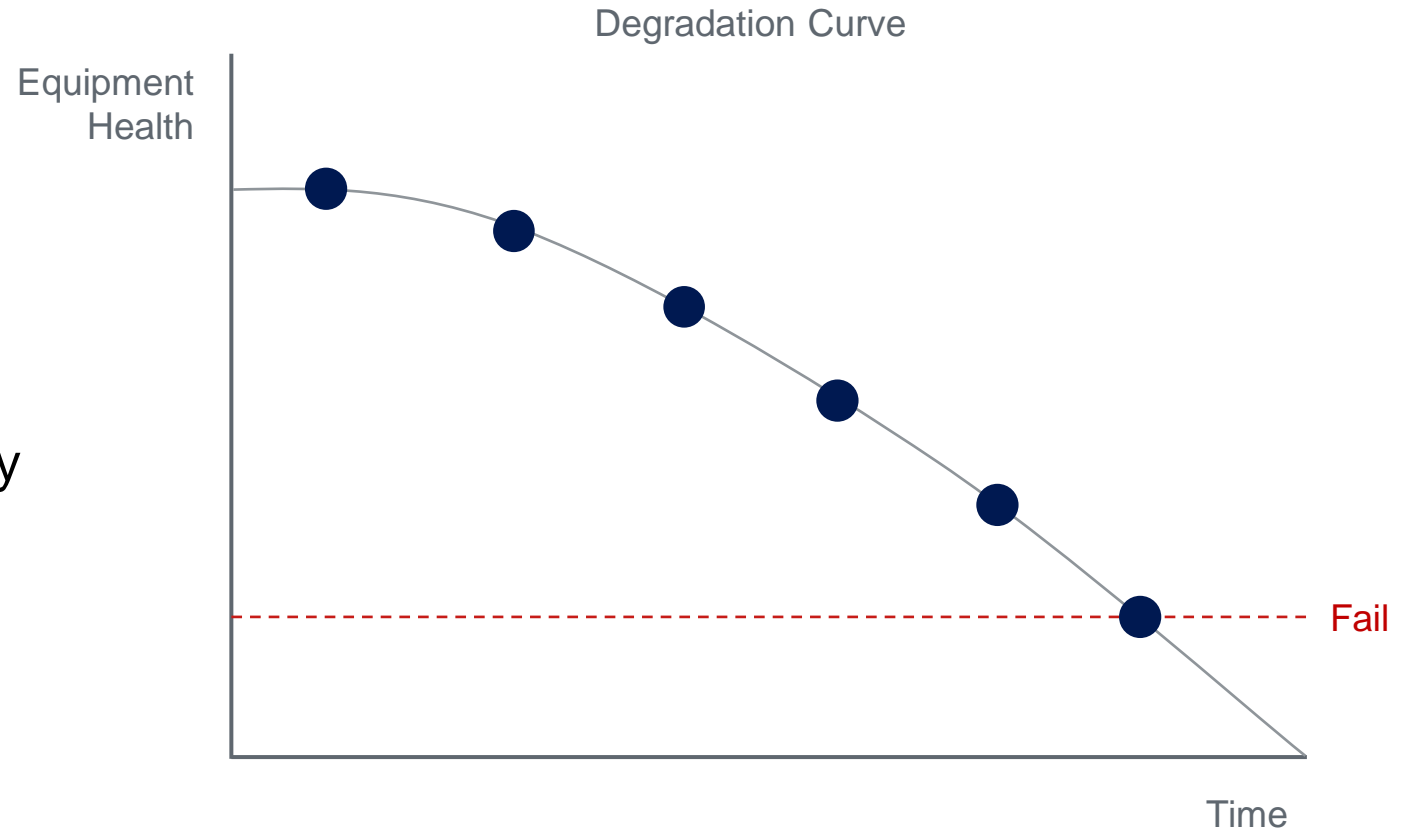

Predictive Maintenance Objective

Identify the optimum time to intervene to prevent unscheduled maintenance and maximize usable condition.

- Leverage data to accurately predict component failure
- Schedule proactive maintenance to maximize operational efficiency

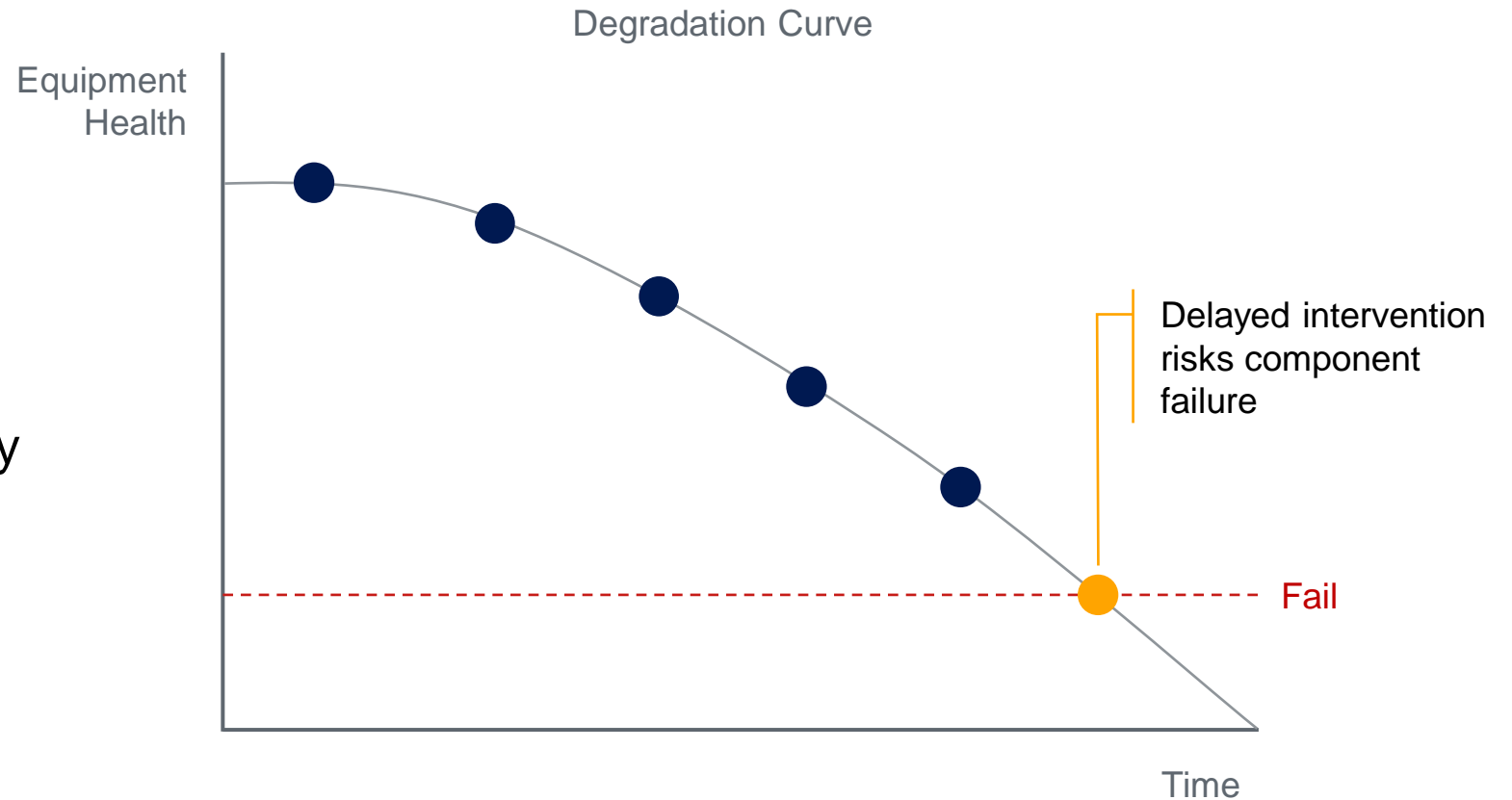

Predictive Maintenance Objective

Identify the optimum time to intervene to prevent unscheduled maintenance and maximize usable condition.

- Leverage data to accurately predict component failure
- Schedule proactive maintenance to maximize operational efficiency

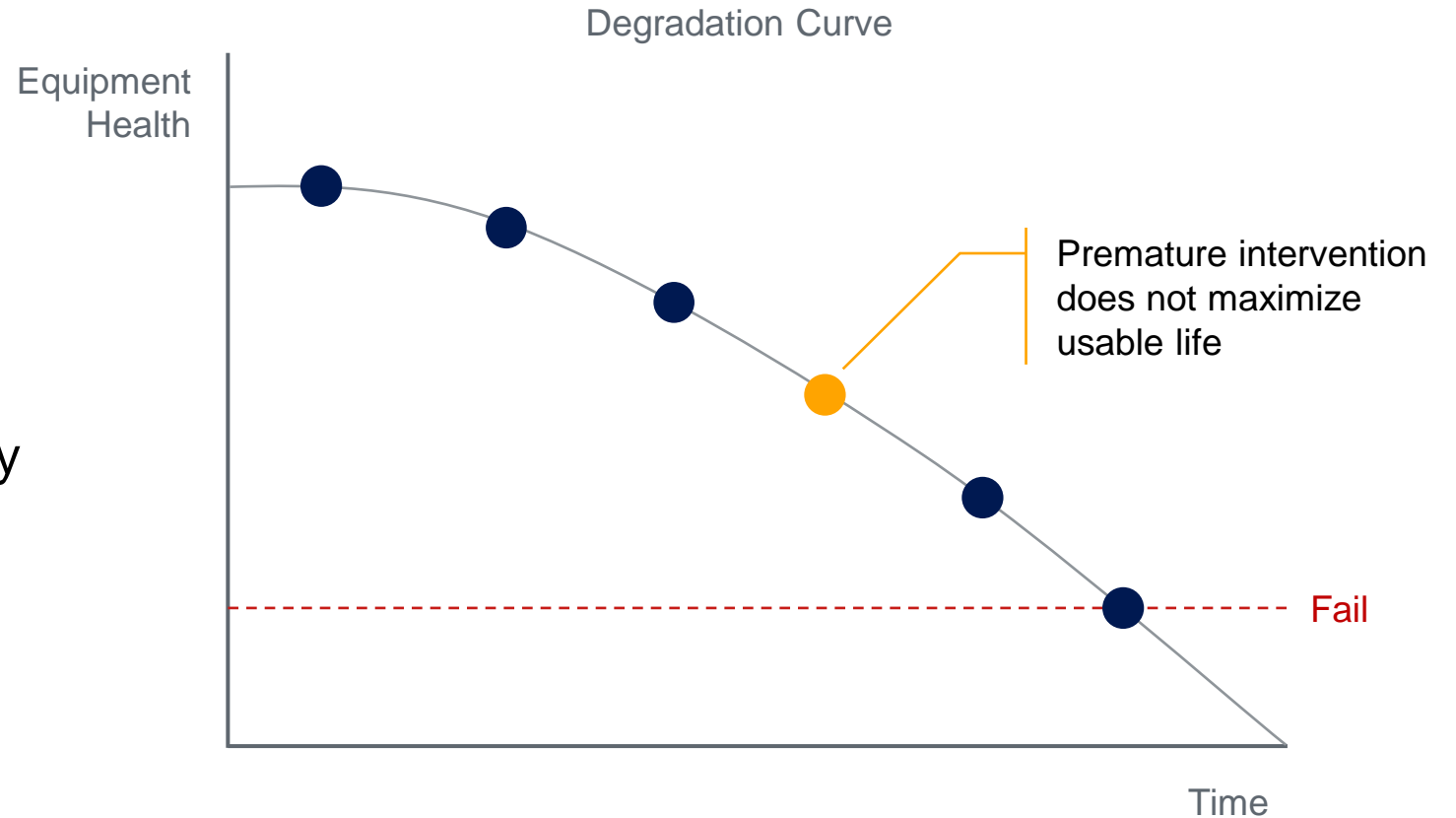

Predictive Maintenance Objective

Identify the optimum time to intervene to prevent unscheduled maintenance and maximize usable condition.

- Leverage data to accurately predict component failure
- Schedule proactive maintenance to maximize operational efficiency

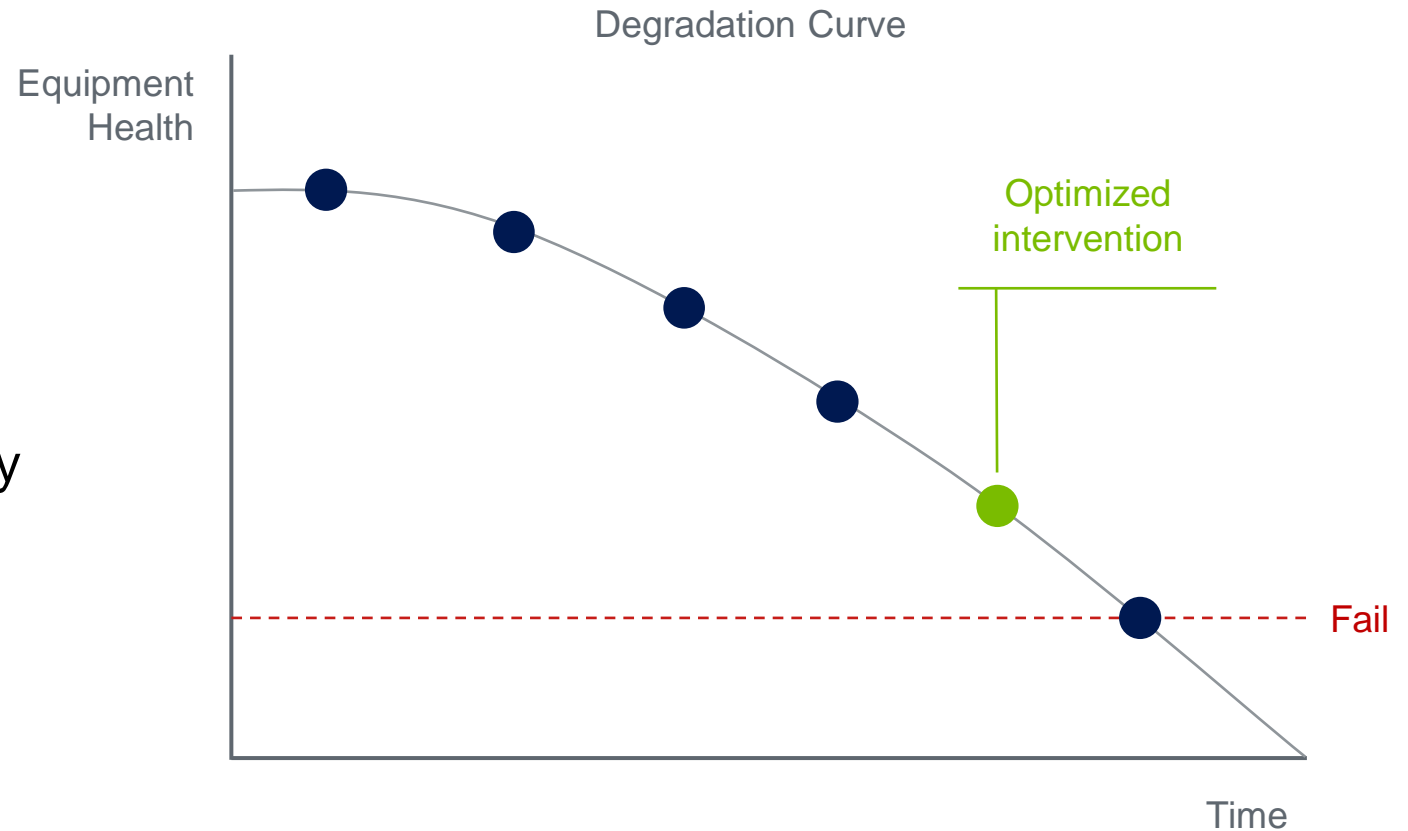

Steps for Effective Predictive Maintenance

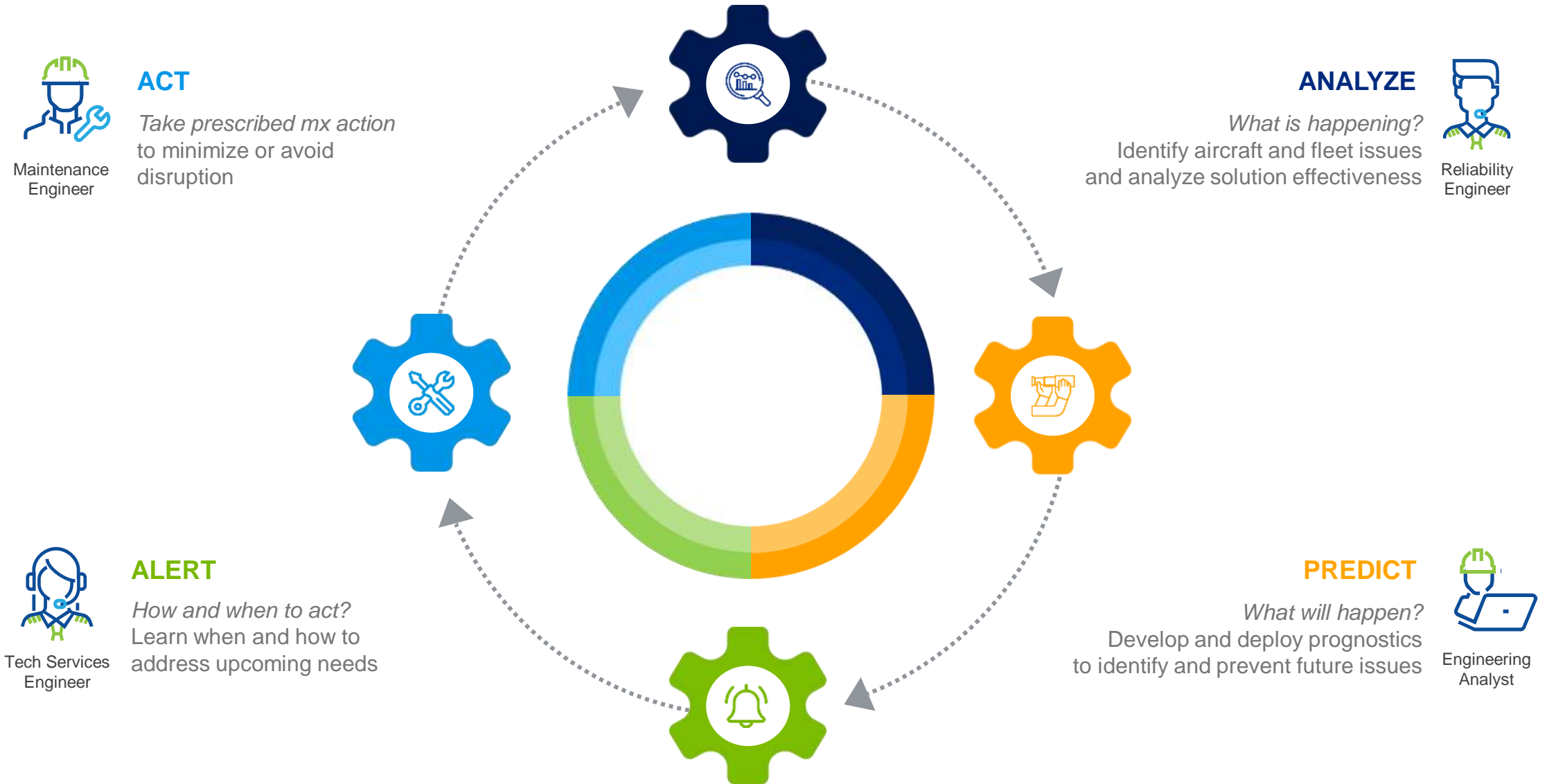

Boeing Predictive Maintenance Solutions

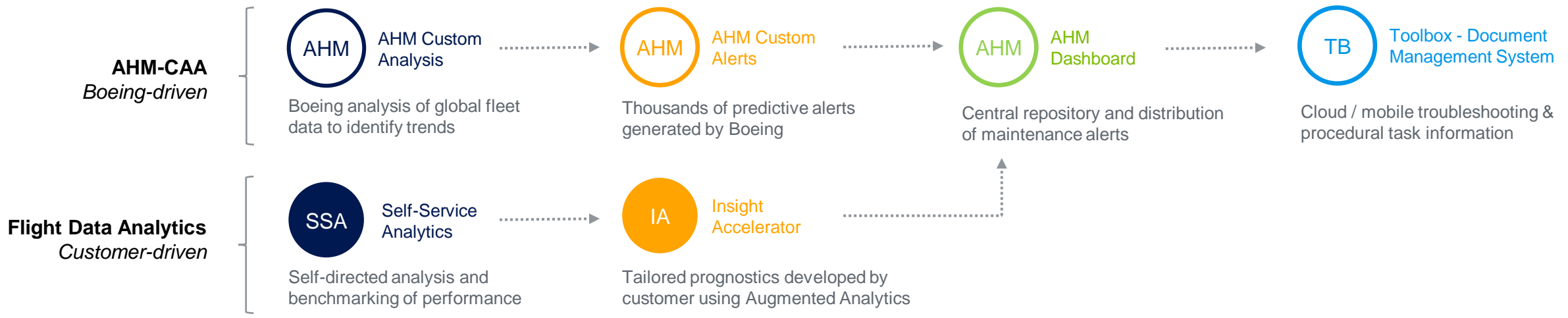
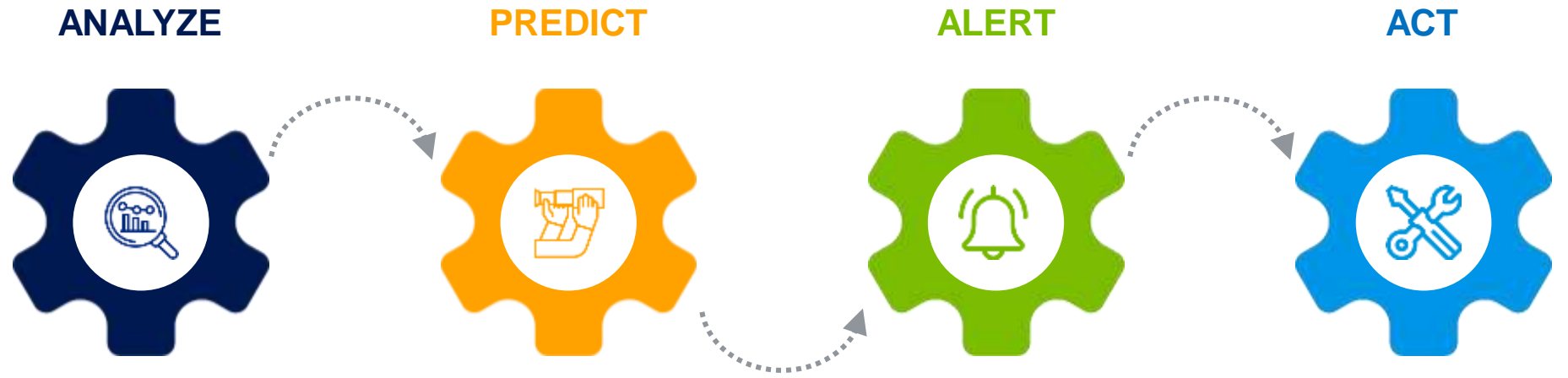

Boeing Predictive Maintenance Solutions

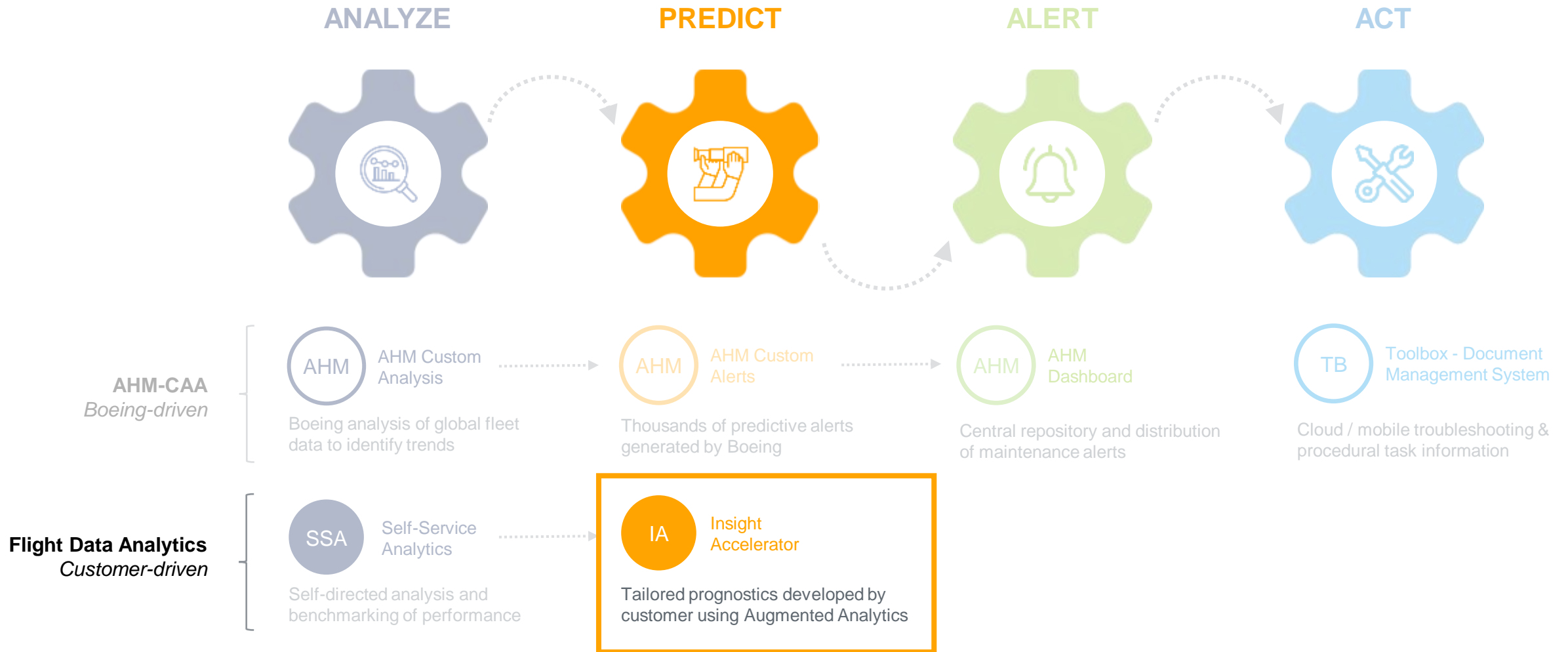

Data-Empowered Airline

“ Augmented analytics is the use of **enabling technologies** such as machine learning and AI to assist with **data preparation, insight generation** and **insight explanation** ...

It also augments the expert and **citizen data scientists** by automating many aspects of data science, machine learning, and AI model development, management and deployment.”

~ Gartner



Insight Accelerator

IA



Insight Accelerator leverages **Augmented Analytics** to guide the Engineering Analyst in discovering, testing, and deploying prognostic algorithms for predictive maintenance.

Insight Accelerator



Insight Accelerator leverages **Augmented Analytics** to guide the Engineering Analyst in discovering, testing, and deploying prognostic algorithms for predictive maintenance.

Fuse historical full flight data, maintenance actions, other data sources



Insight Accelerator



Insight Accelerator leverages **Augmented Analytics** to guide the Engineering Analyst in discovering, testing, and deploying prognostic algorithms for predictive maintenance.

Fuse historical full flight data, maintenance actions, other data sources

Analyze thousands of flights



Insight Accelerator



Insight Accelerator leverages **Augmented Analytics** to guide the Engineering Analyst in discovering, testing, and deploying prognostic algorithms for predictive maintenance.

Fuse historical full flight data, maintenance actions, other data sources

Analyze thousands of flights

Develop prognostic algorithms

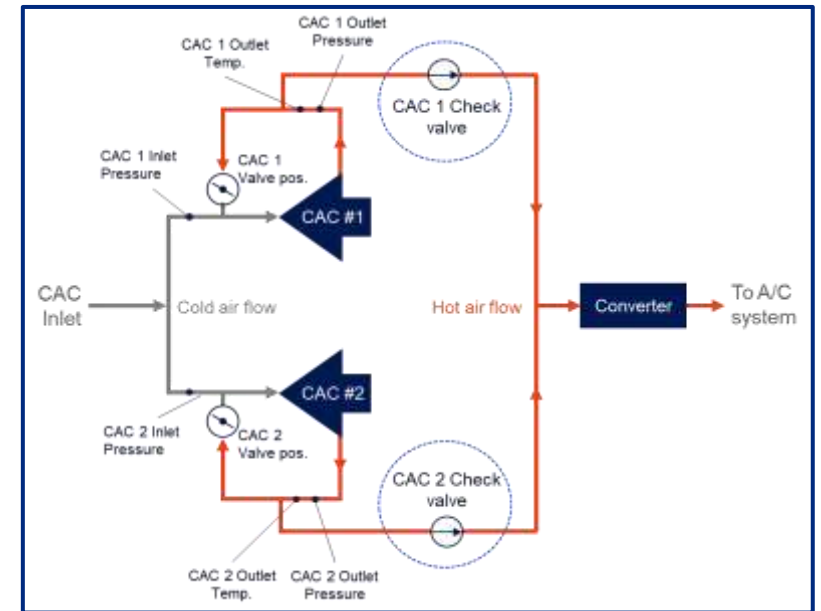

Insight Accelerator



Insight Accelerator leverages **Augmented Analytics** to guide the Engineering Analyst in discovering, testing, and deploying prognostic algorithms for predictive maintenance.

Fuse historical full flight data, maintenance actions, and other data sources

Analyze thousands of flights

Develop prognostic algorithms

Test, tune, and compare multiple prognostic algorithms against historical data

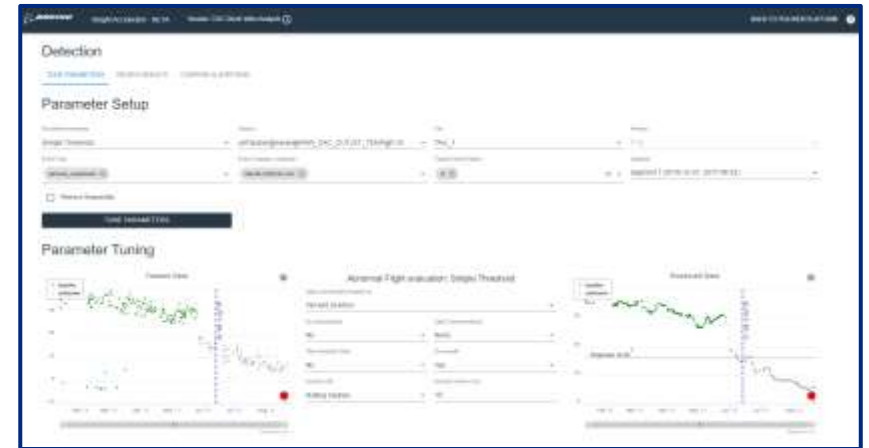

Insight Accelerator



Insight Accelerator leverages **Augmented Analytics** to guide the Engineering Analyst in discovering, testing, and deploying prognostic algorithms for predictive maintenance.

Fuse historical full flight data, maintenance actions, and other data sources

Analyze thousands of flights

Develop prognostic algorithms

Test, tune, and compare multiple prognostic algorithms against historical data

Deploy alerts for optimal maintenance

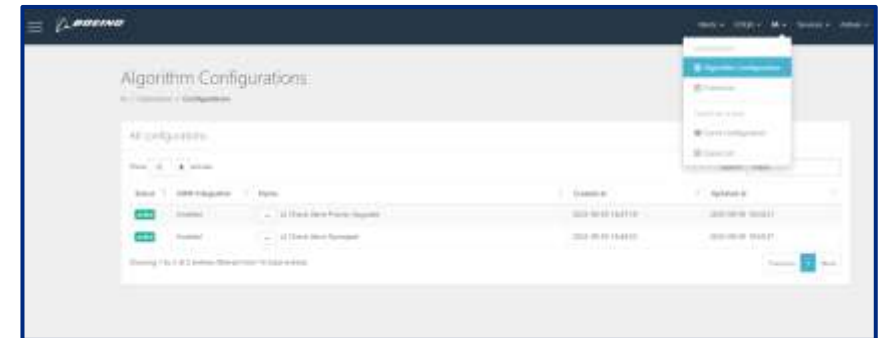

Boeing Predictive Maintenance Solutions

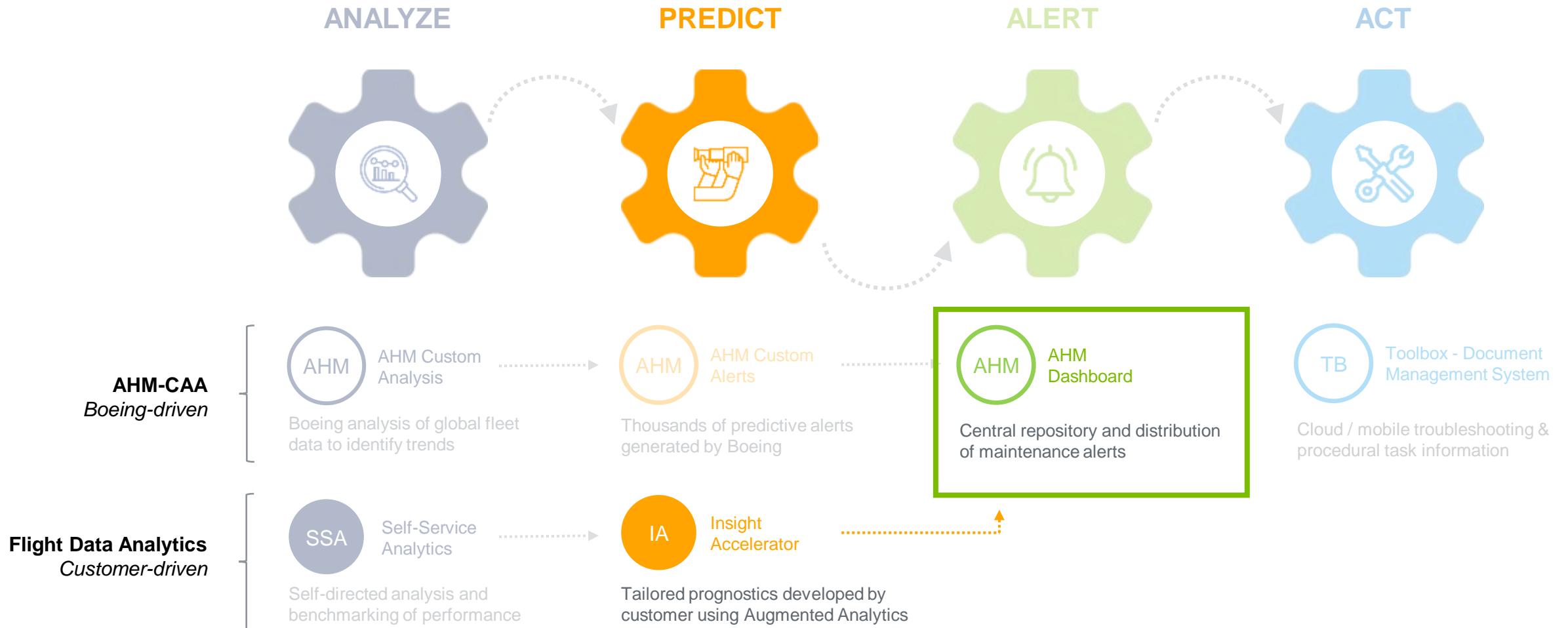

The foundation of analytics empowerment

Faster Time to Insight

“Analysis projects that used to take us months to complete can now be done in a few days.”

- *Insight Accelerator Customer*

More Insights

- Higher rate of prognostic discovery from the analysis team

Higher Quality Insights

- Prognostics operationalized with over 90% precision and recall
- Component inspection costs reduced by over 80%

The foundation of analytics empowerment



DATA



PEOPLE



TECHNOLOGY



Secure, authorized data connectivity with governance

Data analytics tools and applications for optimizing operations

Software applications designed to boost individual and group performance

Organizational processes designed to maximize the ROI for the Analytics Empowered Airline

